

ORIX Aviation Systems Limited

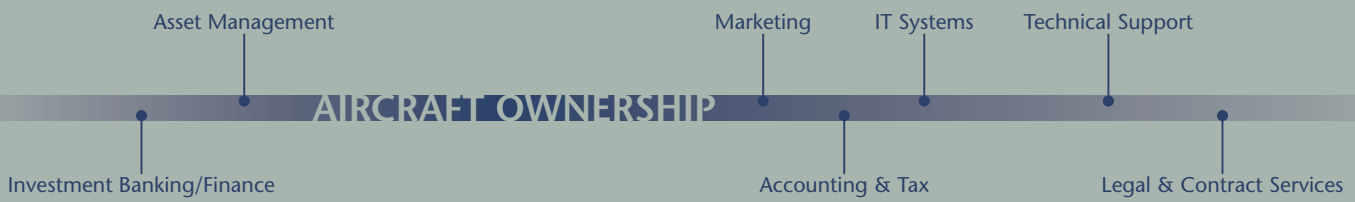

... for proactive aircraft asset management



Getting it right

ORIX Aviation provides a unique range of integrated asset and lease management services to protect and enhance the value of aircraft and engines for lessors, lenders, investors and airlines.

The ORIX service offering covers all aspects of aircraft transactions, including marketing, technical, contract negotiation and structuring, financial and administration. It draws on in-depth knowledge of the aviation industry, gained from years of experience as an operating lessor, asset manager and investor.

We at ORIX Aviation have hands-on transaction experience from the ownership of our own portfolio, and an excellent track record in tailored client advisory with some of the world's leading financial institutions, investors and airlines.

Our expert teams focus on delivering precisely the advice and services that meet the specific needs of our clients. We design and implement complex financial arrangements and resolve intricate legal and technical issues to the highest industry standards. We make sure that deadlines are met, that all necessary action is taken, and that our clients achieve optimum returns on their aviation assets.

For proactive aircraft asset management solutions, ORIX Aviation is the service partner of choice.

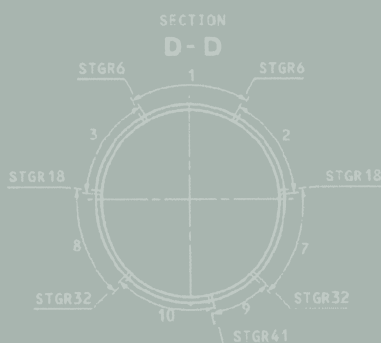

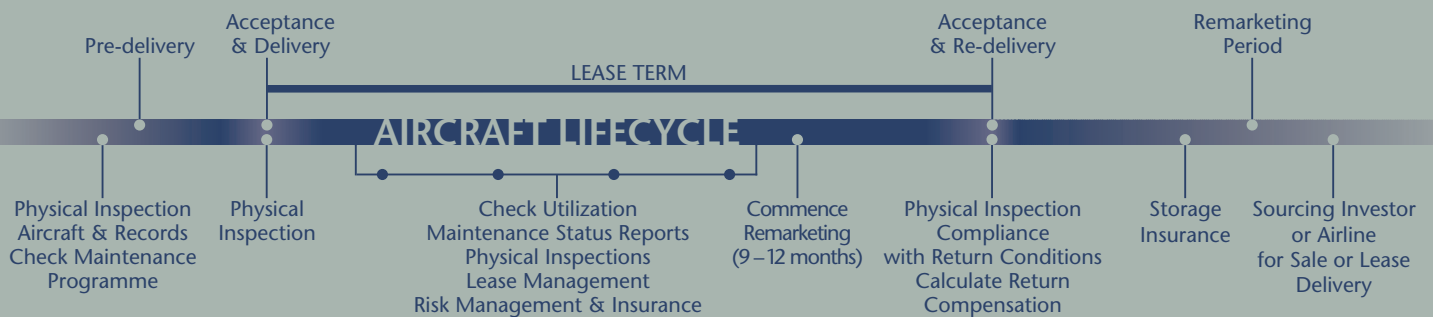

Full life-cycle services

The secret to success in aircraft investment is active management of the asset throughout the operating lease cycle. ORIX Aviation provides the in-house systems and expertise needed by banks and financial owners to take this proactive role. Our full-service capability covers all aspects of aircraft financing and management:

- Aircraft and Engine Marketing
- Contract Negotiation and Structuring
- Aircraft and Engine Technical Services
- Lease Administration Services
- Repossessions and Restructuring
- Advisory Services

Making the right choices

Financing and managing aero equipment entails complex choices all the way through an asset's life-span, from the initial contractual structuring to issues relating to overhaul and maintenance, lease extension and the return of the asset.

We at ORIX Aviation have marketing, legal, technical and asset management expertise in place, supported by highly developed asset management systems and precedents, to serve our clients.

We provide highly competitive lease management solutions for financiers of and investors in narrow and wide bodied commercial aircraft.

Advisory services

The unique market intelligence we gather from our daily dealings with active buyers and investors make us ideally placed to advise our clients on the best terms and conditions available in the market for selling assets and financing owned assets with debt. We have significant experience in running highly successful tendering processes, maximising returns to asset owners from asset sales and debt raising.

Innovative thinking

We are experts in finding innovative and flexible solutions for the many issues facing aircraft owners. Our success is based on the excellent working relationships we have with our clients, and in the shared goal of realizing the full potential of their assets. Our specialty is the development of strategies for optimising fleet deployment and maximising the value of aircraft trades.



Aircraft and Engine Marketing

- marketing/remarketing for lease or sale
- identification of acquisition prospects, aircraft procurement
- sale & leaseback of new and used aircraft
- market analysis reports for investors and owners
- portfolio risk management
- engine and spares trading & leasing opportunities

Contract Negotiations

- legal, technical & financial issues
- return conditions, return compensation
- security & title perfection
- registration, de-registration

Technical Services

- aircraft delivery, re-delivery
- inspecting & auditing maintenance status of aircraft and engines
- engine shop visit planning, supervision & review
- assessment & monitoring of airline maintenance facilities and standards
- general terms agreements with overhaul shops & manufacturers
- flight hour arrangements
- regulatory compliance

Lease Administration

- industry leading asset management system (AMS)
- lease administration & covenant compliance
- security & maintenance deposit administration
- invoicing, rental collections, payments
- insurance administration & review
- regulatory review & compliance monitoring
- managing lease terminations & defaults, lease restructurings

Repossessions

- commercial, technical & contractual issues relating to lease terminations
- defaults, aircraft repossessions & contract restructuring negotiations

Advisory Services

- financial restructuring & refinancing of leases and loans
- Irish registration
- arranging asset sales processes
- raising debt for third-party transactions

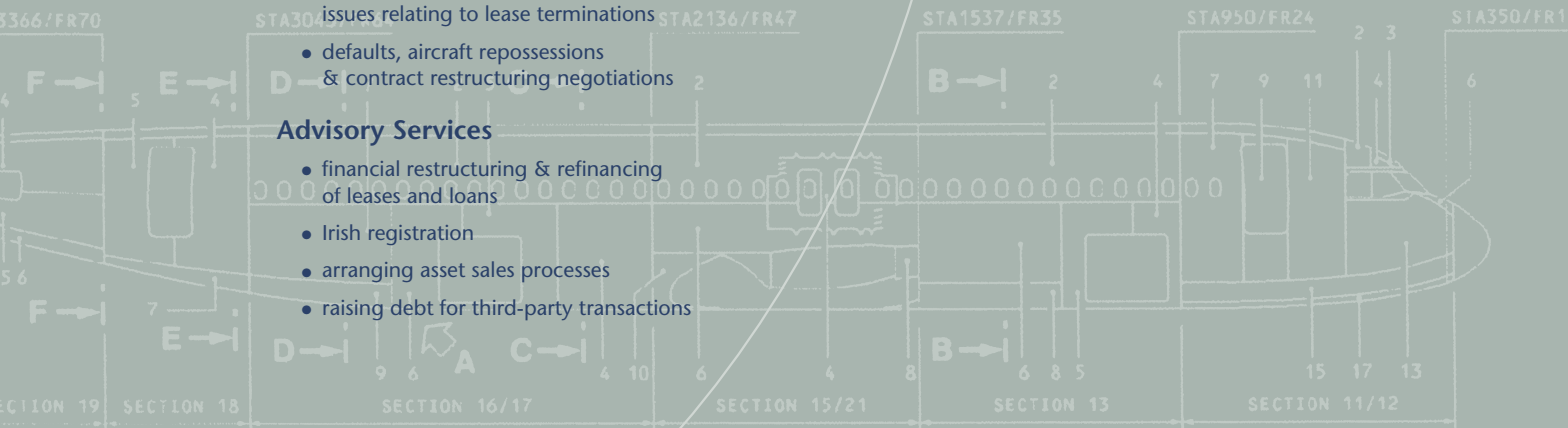
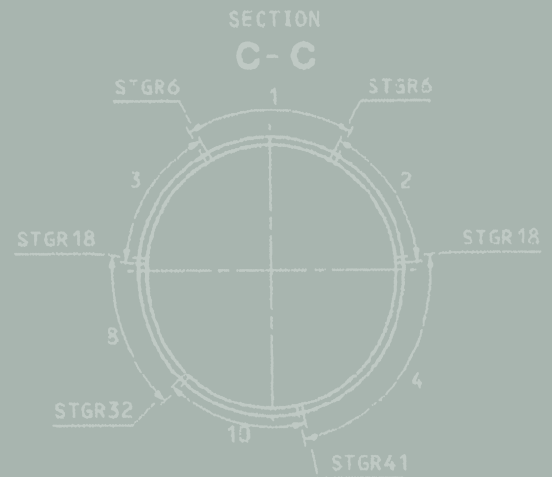
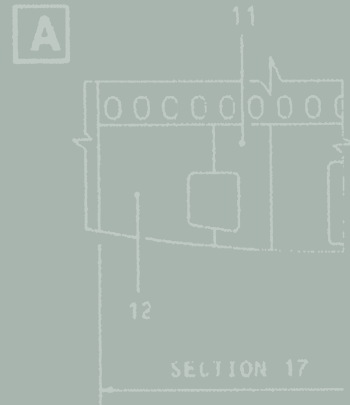



The Company

ORIX Aviation Systems Limited is a commercial aircraft leasing and asset management company providing specialist asset management and advisory services to clients, including some of the world's leading financial institutions, operators and investors.

Founded in 1991, ORIX Aviation is based in Ireland. The company has hands-on experience of asset management from managing its own aircraft portfolio. It has built up its expert systems into fully integrated service lines that support clients in all aspects of asset management. The company currently manages and advises its clients on an extensive fleet of modern commercial aircraft and engines.

ORIX Aviation is a Standard & Poor's approved aviation asset management service provider. Its high quality standards and cohesive organizational structure

allow fresh, innovative thinking and flexibility in a complex business environment. Its strong relationships to its clients and their partners allow it to achieve maximum returns from aircraft assets throughout their working lives. For more details, visit the ORIX Aviation website at www.orixaviation.com!

ORIX Aviation is a member of the ORIX Corporation group of companies. ORIX Corporation is an integrated financial services group based in Tokyo, Japan, providing innovative value-added products and services to both corporate and retail customers. With operations in 23 countries worldwide, ORIX's activities include leasing, corporate and consumer finance, real estate-related finance and development, life insurance and investment banking. For more details, visit the ORIX website at www.orix.co.jp!



ORIX Aviation Systems Limited

Boosterstown Hall
Boosterstown Avenue
Co. Dublin, Ireland
Tel: +353 1 670 0633
Fax: +353 1 670 0644
email: marketing@orixaviation.com
www.orixaviation.com